

Low cost gate valve

«Split body» for easy cleaning



Body material

aluminum

Manual actuator

push rod

DN		Ordering numbers	
mm	inch	ISO-F	JIS
63	2½	12136-PA03	12136-JA03
80	3	12138-PA03	12138-JA03
100	4	12140-PA03	12140-JA03
160	6	12144-PA03	12144-JA03

Pneumatic actuator

double acting
with position indicator
with solenoid

DN		Ordering numbers (specify control voltage)	
mm	inch	ISO-F	JIS
63	2½	12136-PA44	12136-JA44
80	3	12138-PA44	12138-JA44
100	4	12140-PA44	12140-JA44
160	6	12144-PA44	12144-JA44
200	8	12146-PA44	12146-JA44
250	10	12148-PA44	12148-JA44
320	12	12150-PA44	12150-JA44

without position indicator, without solenoid: 121 . . - . **A14**

with position indicator, without solenoid: 121 . . - . **A24**

Larger sizes

DN 400 (16"): see series 14, page 44

DN 400 - 500 (16" - 20"): see series 168, page 60

DN 400 - 1250 (16" - 50"): see series 19, page 68

Sealing materials

Gate: FKM (VITON)

Bonnet: FKM (VITON)

Feedthrough

FKM (VITON) / shaft feedthrough

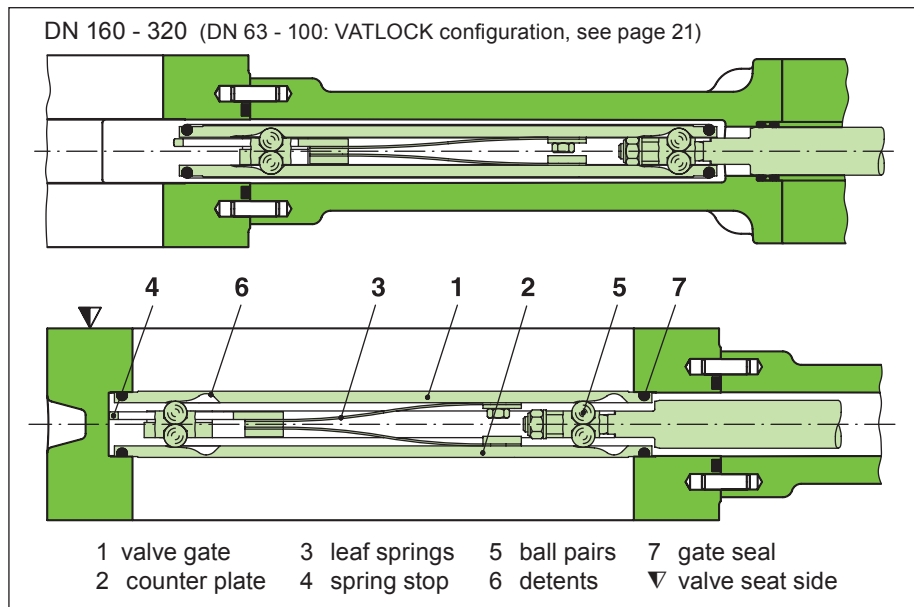

Features

High quality shaft feedthrough

VATLOCK configuration (see glossary)

Low shock during operation

Technical data

Continued next page

Leak rate: body, valve seat	< 1 · 10 ⁻⁹ mbar ls ⁻¹	
Pressure range		
- DN 63 - 200	1 · 10 ⁻⁷ mbar to 1.6 bar (abs)	
- DN 250 - 320	1 · 10 ⁻⁷ mbar to 1.2 bar (abs)	
Differential pressure on the gate		
- DN 63 - 200 / 250 - 320	≤ 1.6 / ≤ 1.2 bar in either direction	
Differential pressure at opening	≤ 30 mbar	
Cycles until first service		
- DN 63 - 100 / 160 - 320	200 000 / 100 000	
Temperature ¹⁾		
- Valve body	≤ 120°C	
- Actuator (manual + pneum.), pos. indicator	≤ 80°C	
- Solenoid	≤ 50°C	
Material	DN 63 - 100	DN 160 - 320
- Valve body	EN AW-5083 (3.3547)	EN AC-42100 (3.2371)
- Valve gate	AISI 304 (1.4301)	EN AW-6060 (3.3206)
- Mechanism	AISI 301 (1.4310)	AISI 301 (1.4310)
	AISI 304 (1.4301)	AISI 304 (1.4301)
	AISI 420 (1.4034)	AISI 420 (1.4034)
Seal: bonnet, gate	FKM (VITON)	
Mounting position	any	
Solenoid	24 VDC, 5.4 W (others see «Options»)	
Position indicator: contact rating		
- Voltage	≤ 250 VAC	≤ 50 VDC
- Current	≤ 2 A	≤ 1.2 A
Valve position	visual (mechanical)	

¹⁾ Maximum values: depending on operating conditions and sealing materials

Options

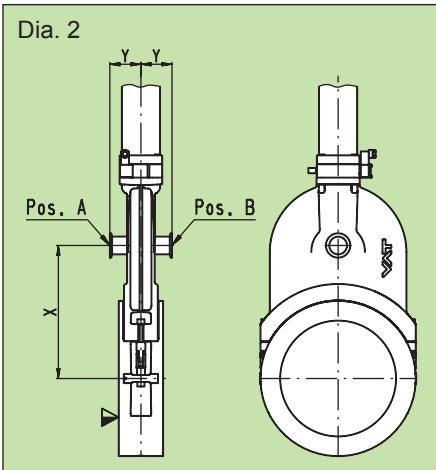
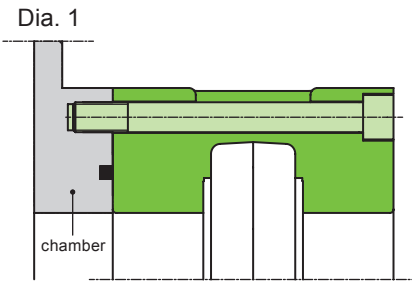

▽ valve seat side

Actuator:

- Solenoid for impulse actuation:
last valve position is maintained at power failure
- Solenoid separate, for external mounting
- Solenoid for 12, 48 VDC
24, 48, 100, 115, 200, 230 V / 50 Hz
24, 100, 115, 200, 230 V / 60 Hz

Valve:

- Through holes in valve body for mounting valve to flat chamber wall (diagram 1)
- Customer specified flanges
- Stainless steel gate for DN 160 - 320 on request
- ASA-LP flanges for DN 100 - 320 on request
- Other sealing materials
- Heater and insulating jacket
- Ports (diagram 2) with seal made of FKM (VITON) for roughing (by-pass), venting or for gauges

DN valve	mm inch	63 2 ½	80 3	100 4	160 6	200 8	250 10	320 12
recommended port	ISO-KF	16	16	25	25	40	40	40
X	mm inch	105 4.13	110 4.33	135 5.31	190 7.48	232 9.13	285 11.22	350 13.78
Y	mm inch	48 1.89	48 1.89	63 2.48	54 2.13	60 2.36	65 2.56	74 2.91

Ordering information for options:

Ordering No. of valve-X (e. g. 12148-PA44-X, X = port ISO-KF40 in position B)

Accessories

Fittings for installation of the valve: series 32

Seal kit

Consisting of seals for bonnet, gate and feedthrough

Ordering No.: see operating manual or price list

Technical data

DN (nominal I. D.)		standard flanges		molecular flow conductance	manual		pneumatic						
		ISO-F	JIS		weight		compressed air pressure min. - max. overpressure		volume of air cylinder		closing or opening time	weight	
mm	inch			ls ⁻¹	kg	lbs	bar	psi	l	ft ³	s	kg	lbs
63	2 ½	63	63	550	3	7	4 - 7	55 - 100	0.16	0.006	1.5	3	7
80	3	80	80	1000	3.8	9	4 - 7	55 - 100	0.2	0.007	1.7	3.8	9
100	4	100	100	2000	4.5	10	4 - 7	55 - 100	0.22	0.008	2	4.5	10
160	6	160	150	6000	9	20	4 - 7	55 - 100	0.5	0.018	2	9	20
200	8	200	200	12000	-	-	4 - 7	55 - 100	0.9	0.032	3	18	38
250	10	250	250	22000	-	-	4 - 7	55 - 100	1.5	0.053	5	25	55
320	12	320	300	33000	-	-	4 - 7	55 - 100	2.8	0.099	7	40	88

Main dimensions

Valve with manual actuator: push rod
DN 63 - 100 (2½" - 4")

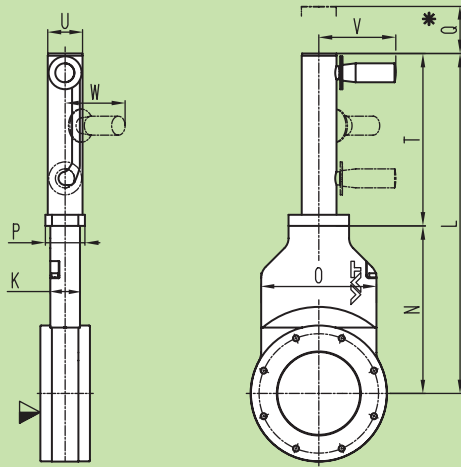

Valve with manual actuator: push rod
DN 160 (6")

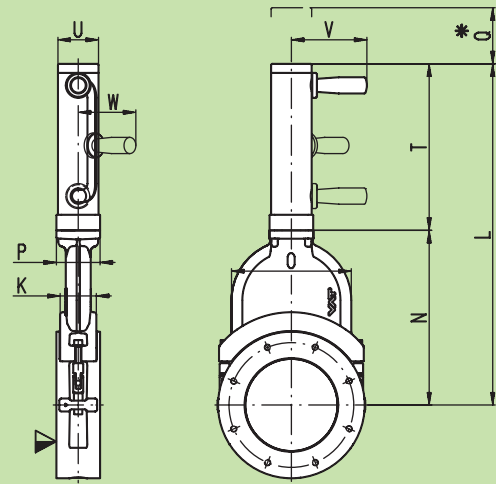

- ▼ valve seat side
- * required for dismantling

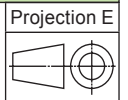

Flange dimensions see page 43

DN	mm inch	63 2½	80 3	100 4
K	mm inch	36 1.42	36 1.42	36 1.42
L	mm inch	329.5 12.97	363 14.29	413 16.26
N	mm inch	155.5 6.12	173.5 6.83	203.5 8.01
O	mm inch	100 3.94	118 4.65	140 5.51
P	mm inch	48 1.89	48 1.89	48 1.89
Q	mm inch	25 0.98	25 0.98	25 0.98
T	mm inch	174 6.85	189.5 7.46	209.5 8.25
U	mm inch	43 1.69	43 1.69	43 1.69
V	mm inch	94 3.7	94 3.7	94 3.7
W	mm inch	75 2.95	75 2.95	75 2.95

DN	mm inch	160 6		
K	mm inch	58 2.28		
L	mm inch	547 21.54		
N	mm inch	280 11.02		
O	mm inch	192 7.56		
P	mm inch	70 2.76		
Q	mm inch	60 2.36		
T	mm inch	267 10.51		
U	mm inch	65 2.56		
V	mm inch	122 4.8		
W	mm inch	95 3.74		

Main dimensions

Valve with pneumatic actuator: double acting
DN 63 - 100 (2½" - 4")

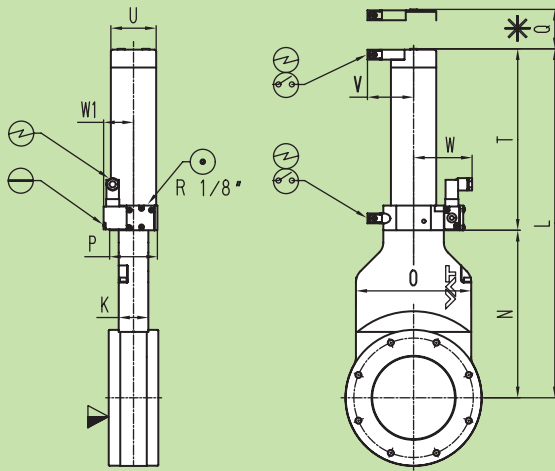

Valve with pneumatic actuator: double acting
DN 160 - 320 (6" - 12")

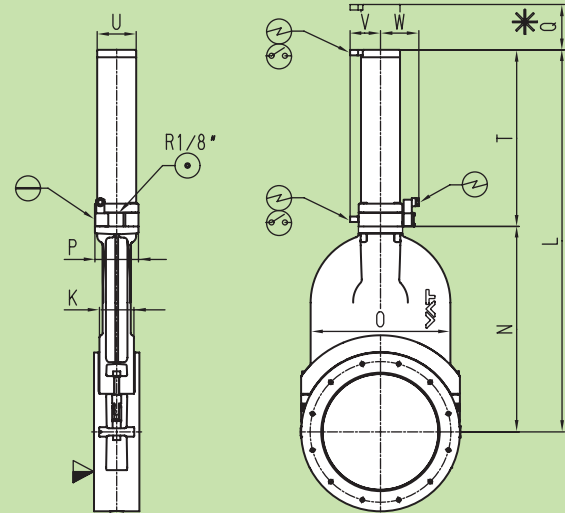

- ▽ valve seat side
- * required for dismantling
- ⊕ electrical connection
- ⊙ compressed air connection
- ⊖ emergency operation
- ⊗ position indicator

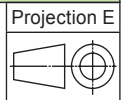

Flange dimensions see page 43

DN	mm	63	80	100	
	inch	2½	3	4	
K	mm	36	36	36	
	inch	1.42	1.42	1.42	
L	mm	341.5	375	425	
	inch	13.45	14.76	16.69	
N	mm	155.5	173.5	203.5	
	inch	6.12	6.83	8.01	
O	mm	100	118	140	
	inch	3.94	4.65	5.51	
P	mm	58	58	58	
	inch	2.28	2.28	2.28	
Q	mm	25	25	25	
	inch	0.98	0.98	0.98	
T	mm	186	201.5	221.5	
	inch	7.32	7.93	8.72	
U	mm	55	55	55	
	inch	2.17	2.17	2.17	
V	mm	56	56	56	
	inch	2.2	2.2	2.2	
W	mm	72	72	72	
	inch	2.83	2.83	2.83	
W1	mm	36.5	36.5	36.5	
	inch	1.44	1.44	1.44	

DN	mm	160	200	250	320
	inch	6	8	10	12
K	mm	58	66	76	96
	inch	2.28	2.6	2.99	3.78
L	mm	547	688	843	1029
	inch	21.54	27.09	33.19	40.51
N	mm	280	363.5	453	558
	inch	11.02	14.31	17.83	21.97
O	mm	192	240	308	370
	inch	7.56	9.45	12.13	14.57
P	mm	70	80	96	114
	inch	2.76	3.15	3.78	4.49
Q	mm	60	80	100	120
	inch	2.36	3.15	3.94	4.72
T	mm	267	324.5	390	471
	inch	10.51	12.78	15.35	18.54
U	mm	65	75	86	106
	inch	2.56	2.95	3.39	4.17
V	mm	57	62	67	75
	inch	2.24	2.44	2.64	2.95
W	mm	71.5	76.5	84.5	93.5
	inch	2.82	3.01	3.33	3.68

Flange dimensions

ISO-F DN 63 - 320 (2½" - 12")

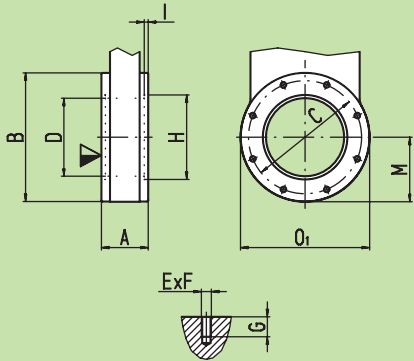

DN	mm inch	63 2½	80 3	100 4	160 6	200 8	250 10	320 12
A	mm inch	60 2.36	60 2.36	60 2.36	70 2.76	80 3.15	100 3.94	120 4.72
B	mm inch	130 5.12	145 5.71	165 6.5	235 9.25	288 11.34	350 13.78	425 16.73
C	mm inch	110 4.33	125 4.92	145 5.71	200 7.87	260 10.24	310 12.2	395 15.55
D	mm inch	65 2.56	80 3.15	100 3.94	150 5.91	200 7.87	261 10.27	318 12.52
E x F		4 x M8	8 x M8	8 x M8	8 x M10	12 x M10	12 x M10	12 x M12
G	mm inch	12 0.47	12 0.47	12 0.47	16 0.63	16 0.63	16 0.63	20 0.79
H	mm inch	70 2.76	83 3.27	102 4.02	153 6.02	213 8.39	- -	- -
I	mm inch	3 0.12	3 0.12	3 0.12	5 0.2	5 0.2	- -	- -
M	mm inch	65.5 2.58	73 2.87	83 3.27	117.5 4.63	144 5.67	175 6.89	212.5 8.37
O1	mm inch	131 5.16	146 5.75	166 6.54	237 9.33	290 11.42	352 13.86	428 16.85

**JIS B 2290: 1998 / ISO 1609
DN 65 - 300 (2½" - 12")**

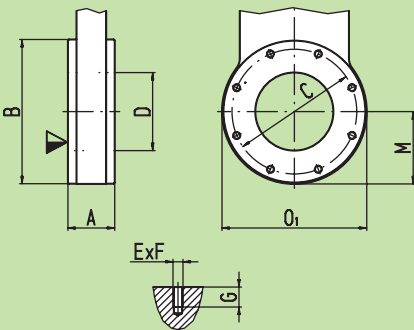

DN	mm inch	65 2½	80 3	100 4	150 6	200 8	250 10	300 12
A	mm inch	60 2.36	60 2.36	60 2.36	70 2.76	80 3.15	100 3.94	120 4.72
B	mm inch	145 5.71	160 6.3	185 7.28	235 9.25	288 11.34	350 13.78	425 16.73
C	mm inch	120 4.72	135 5.31	160 6.3	210 8.27	270 10.63	320 12.6	370 14.57
D	mm inch	65 2.56	80 3.15	100 3.94	150 5.91	200 7.87	261 10.27	318 12.52
E x F		4 x M10	4 x M10	8 x M10	8 x M10	8 x M12	12 x M12	12 x M12
G	mm inch	12 0.47	12 0.47	12 0.47	16 0.63	16 0.63	16 0.63	20 0.79
M	mm inch	73 2.87	81 3.19	93 3.66	117.5 4.63	144 5.67	175 6.89	212.5 8.37
O1	mm inch	146 5.75	161 6.34	186 7.32	237 9.33	290 11.42	352 13.86	428 16.85

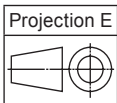

▼ valve seat side